

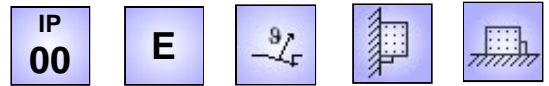

Type series FKK.. 3..

5,0 – 250 kW, in duct design



Steel-grid fixed resistor unit, degree of protection IP 00 integrated in a duct section for integration by the user into existing or new exhaust air installations, in a zinc steel sheet duct with attached terminal box and optional temperature switch.

### Technologies

- for middle or high power ratings
- low priced solution for existing forced ventilation provided by the customer
- continuous dissipation up to 250 kW
- prepared for integration into customer's duct.
- For exhaust air temperatures up to 60°C
- optional with temperature switch wired on two terminals, type designation would be FKKEQ 3...

We provide ceramic insulated flat or bolt terminals of 35 A up to 400 A and mount the required terminals into an attached terminal box.

On behalf of a large range of dimensions, vertically as well as horizontally, we realize all kinds of duct cross sections.

### Application

An important application is the use as load resistor for emergency power units.

In cases where a diesel power unit is to be protected by a base load against "wear" due to small load or when necessary or compulsory load tests of efficiency of the power unit must be accomplished.

We are specialists in customized solutions!

### Special designs

- integration into ducts, provided by the customer, type series FKKF..
- integration kit for integration by the user
- up to 5 blocks can be mounted on top of each other
- with integration of 2 resistor sets in a row
- with wind indicator monitoring

### Electrical and mechanical data

Type FKK. 3.. without TS, FKKEQ. 3.. with TS	max. typical power in kW at 40°C and 100% DCF	max. number of steel-grids corresp. to given device combination (n x m)	dimensions in mm						max. weight in kg
			max. block # (n)	duct height		duct width			
A	B	max. SG-# (m)		C	D				
F.. 31215..	15,0	15	1	415	475	15	415	475	25
F.. 32236..	37,5	36	2	450	510	18	450	510	35
F.. 32242..	45,0	42	2	550	610	21	500	560	47
F.. 32248..	50,0	48	2	600	660	24	550	610	50
F.. 32354..	60,0	54	2	650	710	27	630	690	55
F.. 33384..	95,0	84	3	690	750	28	650	710	85
F.. 33390..	100	90	3	720	780	30	700	760	88
F.. 33399..	112,5	99	3	750	810	33	765	825	95
F.. 34444..	160	144	4	900	960	36	810	870	135
F.. 34460..	180	162	4	1000	1060	41	900	960	150

This table represents only a selection of what can be combined concerning duct dimensions. Other combinations and other dimensions are available, of course. All numbers of steel-grids corresponding to our types between 15 pcs. (15 kW) und 264 pcs. (250 kW) are available. Type code and selection of units see Technical Details pages T613E to T620E. Please let us know your specific case of application. We will meet exactly your requirements.

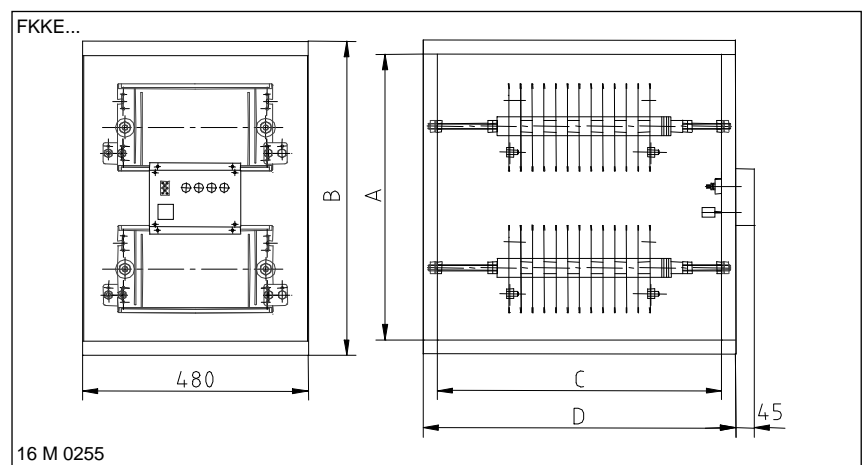

### Example of dimensioning and selection of a specific unit:

Please contact us, we will be glad to work on a detailed offer for you!